

A Novel Molecular Descriptor Derived from Weighted Line Graph

CHANDANA ADHIKARI AND BIJAY KUMAR MISHRA*

Centre of Studies in Surface Science and Technology, School of Chemistry, Sambalpur University, Jyoti Vihar, Odisha 768019, India

ARTICLE INFO

Article History:

Received: 4 May 2017

Accepted: 3 August 2017

Published online 30 September 2019

Academic Editor: Saeed Masoum

Keywords:

Weighted line graph

Molecular descriptor

Physicochemical properties

ABSTRACT

The Bertz indices, derived by counting the number of connecting edges of line graphs of a molecule were used in deriving the QSPR models for the physicochemical properties of alkanes. The inability of these indices to identify the hetero centre in a chemical compound restricted their applications to hydrocarbons only. In the present work, a novel molecular descriptor has been derived from the weighted line graph of the molecular structure and applied in correlating the physicochemical properties of alkane isomers with these descriptors. A weight is tagged at the vertex of the line graph, which consequently modifies the weight of the edge. These descriptors were found to classify the alkane isomers and served well in deriving the QSPR models for various physicochemical properties. The mathematical calculations include the quantitative treatment on the role of substituents (alkyl) in governing the properties under study of the alkane isomers. Further, the use of weighted line graph in the enumeration of the topological index opens up a new vista on application to heteroatomic systems.

© 2019 University of Kashan Press. All rights reserved

1. INTRODUCTION

Owing to the ease in handling vertex and edges with simple graph theoretical principles a large number of topological parameters have been enumerated and used in various quantitative structure property/activity relationships [1]. Conversion of graph to matrices have also contributed a lot to this field of studies and also trespassed in to the field of quantum mechanical calculations [2]. Line graphs (LG), obtained by considering each covalent bond a vertex and connectivity of bonds as edge in hydrogen depleted molecular graphs, have been used to derive molecular descriptors and have been widely used in QSPR studies [3–10].

*Corresponding author (Email: bijaym@hotmail.com).

DOI: 10.22052/ijmc.2017.84168.1287

Subsequently some novel molecular descriptors have been derived from the line graphs. The spectral moments of line graphs have been used as the molecular descriptors to describe the ^{13}C NMR chemical shift of alkanes [11–13]. A folding degree index for some steroid compounds have been evaluated by using iterated line graphs (ILG) and has been used in the study of drug designing [14]. Guevara compared QSPR models obtained with k -fragmental connectivity indices with that obtained from the molecular connectivity indices of ILGs [15]. The mathematical aspects of LG and ILGs have been extensively studied in the recent years [16–28].

Herein, we have made an attempt to tag the vertex of line graph with a weight to derive some novel molecular descriptors.

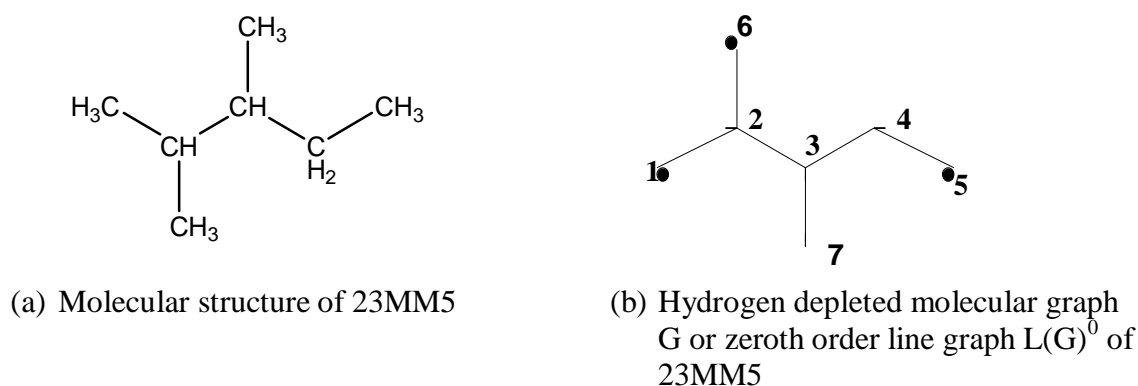

Figure 1. Representation of molecular structure and hydrogen depleted molecular graph G of 23MM5.

2. ENUMERATION OF WEIGHTED LINE GRAPH INDEX

A weighted line graph is the line graph $Lw(G)$ of a molecular graph G in which each vertex (u_i) of $Lw(G)$ is assigned with a nonnegative number $w(u_i)$, called the weight of u_i . As example, the molecular structure and line graph of 2,3-dimethyl pentane (23MM5) can be presented as shown in Figures 1(a) and 1(b). Figures 2(a, b and c) represent the weighted linegraphs of zeroth, first and second order of 23MM5 respectively. Starting with the hydrogen depleted molecular graph G or the zeroth order line graph $L(G)^0$, each vertex of the LG is assigned with a value equal to the weight on the connecting edge of G attached to the vertex ' v_i ' to obtain zero order weighted line graph $Lw(G)^0$. The weight of the edge of G is the weight of the vertex ($w(u_i)$) is given by

$$v_{i-j} = w(u_i) = \frac{1}{\sqrt{\delta_i \delta_j}} \quad \dots(1)$$

where δ_i and δ_j are the degree (weight) of the vertices v_i and v_j respectively. The molecular descriptor for the zeroth order weighted line graph is defined as

$$L_0 = \sum_{edges} v_{i-j} = \sum_{edges} \frac{1}{\sqrt{\delta_i \delta_j}} \quad \dots(2)$$

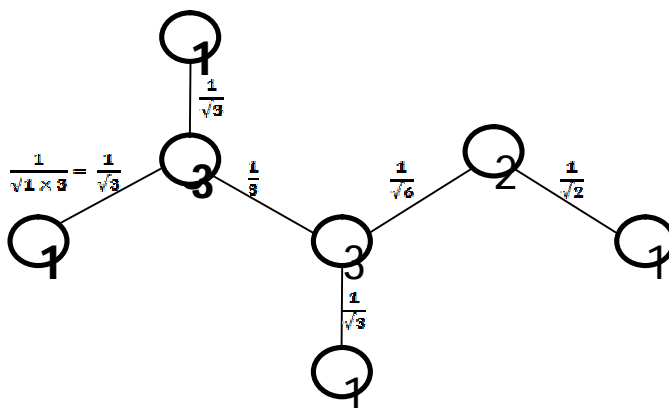

$$\theta_0 = 6, L_0 = \sum_{edges} v_{i-j} = 3.1806$$

(a) Zeroth order weighted line graph of 23MM5, $Lw(G)^0$

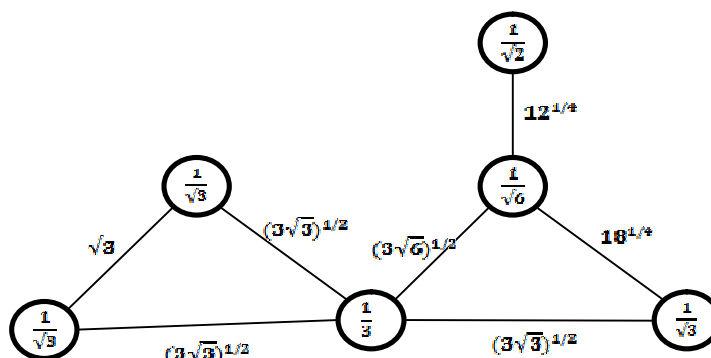

$$\theta_1 = 7, L_1 = \sum_{edges} v_{i-j} = 15.2022$$

(b) 1st order weighted line graph of 23MM5, $Lw(G)^1$

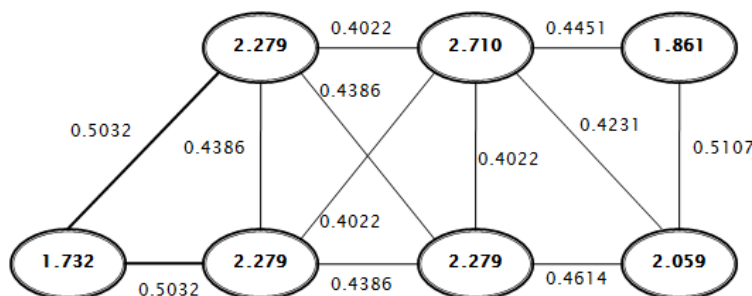

$$\theta_2 = 12, L_2 = \sum_{edges} v_{i-j} = 5.3696$$

(c) 2nd order weighted line graph of 23MM5, $Lw(G)^2$

Figure 2. Representations of Weighted Line Graph (a) $Lw(G)^0$, (b) $Lw(G)^1$ and (c) $Lw(G)^2$ of 23MM5 and molecular descriptors θ_i (Bertz index = number of edges in the respective Line Graph) and L_i

In a similar manner, by considering the edge of $Lw(G)^0$ as the vertex and their connectivity, $Lw(G)^1$ is constructed. The molecular descriptors for higher order $Lw(G)$ s can be determined and denoted as L_i , $i=0, 1, 2, \dots$, which is the sum of the $Lw(G)$ edges. The structural difference between the alkane isomers is clearly observed in the plot of molecular descriptor L_2 vs physicochemical properties of alkanes. Some dummy descriptors or indicators parameters (IP) are used to explain the structural differences of alkane isomers obtained from the plot. One or zero value is assigned for the presence or absence of a particular class of substituent in the structure. A Free-Wilson matrix [29] has been constructed with all the *ad hoc* indicators (seven in the present study) (Table 3). The physicochemical properties of 72 alkanes (C4–C9) are correlated with the weighted line graph theoretical molecular descriptor L_2 along with the indicator parameters (IP) to obtain a correlation equation,

$$P = a_1L_2 + a_2 IP_1 + a_3 IP_2 + a_4 IP_3 + a_5 IP_4 + a_6 IP_5 + a_7IP_6 + a_8 IP_7 + b \quad \dots(3)$$

where P is the physicochemical property collected from Needham-Wei-Seybold data base [30,31], ' a_i ' represents the sensitivity or the contribution of the topological parameter towards the physicochemical property of the testing molecules and 'b' is a constant. The ratio of the coefficient of IP for a particular class of substituent to that of L_2 , ' a_i/a_1 ' gives the contribution of that class of substituent in the molecular structure towards the physicochemical property under consideration. ' a_i/a_1 ' values for all the physicochemical properties taken in the present study are determined and it is found that the values are approximately equal (Table 4). The average of ' a_i/a_1 ' for all the property is taken as the contribution of that particular class of substituent towards the physicochemical properties of the molecules under consideration and termed as SP (Table 4). Instead of taking seven indicator parameters (IP), a single *ad hoc* descriptor SP is taken. The value of SP indicates the weight of a particular class of substituent in the molecular structure. Multiple regression analysis is then carried by taking the structural descriptor L_2 and the *ad hoc* descriptor SP with the physicochemical properties of C3–C9 hydrocarbons. It is found that the descriptor successfully explains the structural difference between the alkane isomers and gives a good model for the surface tension of alkane series.

3. ANALYSIS OF WEIGHTED LINE GRAPH INDEX (LI)

From normal hydrogen depleted molecular graph, Bertz indices (θ_i) have been derived by counting the number of edges of the corresponding line graph and have been applied in QSPR studies of alkanes [6–10]. It has limitations for heteroatomic systems, as simple line graphs cannot differentiate heteroatoms from carbon atom. Though core electrons play major roles in quantum mechanical characteristics of heteroatoms, most physicochemical properties and even some biological activities are influenced by the valence electrons. In

the present work, edges of the line graphs are modified with the contribution from the valence electrons of the concerned heteroatom. Akin to enumeration of Kier connectivity index, edges of the line graphs are labeled with a weight and the sum over of the weights has been considered as the weighted line graph index (L_i). L_0 refers to the zero order line graph index, which is same as the χ^1 index of Kier. From the higher order line graphs, the higher order parameters, L_i , have been calculated and given in Table 1. Except L_2 of butane, L_i for all the other structures are found to be more than one. However, the values are not as large as the corresponding θ_i s.

The weighted line graph parameter L_0 has a homology genesis exhibiting an increment of 0.5 per increase in methylene unit in a linear graph. It is obvious, as each insertion of a methylene unit adds a weight as $(\delta_i \delta_j)^{-1/2}$ where $\delta_i = \delta_j = 2$. In branched structure, which appears as a tree graph, the increment depends on the degree of the adjacent carbon at the point of insertion.

Table 1. Molecular descriptors of weighted line Graphs of alkane isomers.

Sl.no.	Alkane	L_0	L_1	L_2
1	3	1.4140	1.3635	
2	4	1.9142	3.3635	0.5946
3	2M3	1.7320	5.1961	1.7320
4	5	2.4142	5.3635	1.0905
5	2M4	2.2700	7.7127	2.5656
6	22MM3	2	12	6
7	6	2.9142	7.3635	1.5905
8	2M5	2.7700	9.7465	2.9991
9	3M5	2.8077	10.2914	3.3337
10	22MM4	2.5606	15.1352	6.8878
11	23MM4	2.6427	12.5821	4.6451
12	7	3.4142	9.3635	2.0905
13	2M6	3.2700	11.7465	3.5012
14	3M6	3.3079	11.9730	3.8176
15	3E5	3.3460	12.9320	4.0347
16	22MM5	3.0606	17.1953	7.2736
17	23MM5	3.1806	15.2022	5.3696
18	24MM5	3.1258	14.1526	4.8693
19	33MM5	3.1210	18.3420	7.7327
20	223MMM4	2.9433	20.5274	8.9967
21	8	3.9142	11.3635	2.5905
22	2M7	3.7700	13.7465	4.0012
23	3M7	3.8079	14.3251	4.2728
24	4M7	3.8079	14.3591	4.2078
25	3E6	3.8460	14.9658	4.4087
26	22MM6	3.5606	19.1953	7.7773

Table 1. (Continued)

Sl.no.	Alkane	L ₀	L ₁	L ₂
27	23MM6	3.6806	17.2352	5.8086
28	24MM6	3.6638	16.7311	5.6428
29	25MM6	3.6258	16.1298	5.4136
30	33MM6	3.6213	20.4021	8.1217
31	34MM6	3.7187	17.8225	6.0973
32	3E2M5	3.7187	17.8844	6.0260
33	3E3M5	3.6819	21.6204	8.5333
34	223MMM5	3.4812	23.1796	9.6872
35	224MMM5	3.4164	21.6188	9.1144
36	233MMM5	3.5039	23.7820	9.4125
37	234MMM5	3.5533	20.1411	7.3782
38	2233MMMM4	3.2500	28.9700	13.3486
39	9	4.4142	13.3635	3.0905
40	2M8	4.2700	15.7465	4.5012
41	3M8	4.3079	16.3251	4.7728
42	4M8	3.8995	16.3591	4.7099
43	3E7	4.3460	16.9658	4.9772
44	4E7	4.3460	16.9998	4.9157
45	22MM7	4.0606	21.1954	8.2773
46	23MM7	4.1806	19.2360	6.3107
47	24MM7	4.1638	18.7649	5.9611
48	25MM7	4.1638	18.7083	6.1852
49	26MM7	4.1258	18.1298	5.4038
50	33MM7	4.1213	22.4021	8.6254
51	34MM7	4.2186	19.8563	6.1675
52	35MM7	4.2019	19.3098	6.4164
53	44MM7	4.1213	22.4623	8.5108
54	23ME6	4.2187	19.9182	6.4684
55	24ME6	4.2019	19.3718	6.349
56	33ME6	4.1819	23.6805	8.9254
57	34EM6	4.8339	20.5046	6.7568
58	223MMM6	3.9812	25.2134	10.1274
59	224MMM6	3.9543	24.1974	9.4038
60	225MMM6	3.9164	23.5784	9.7283
61	233MMM6	4.0039	26.1604	10.1603
62	234MMM6	4.0913	22.7612	8.1073
63	235MMM6	4.0364	21.6421	7.6815
64	244MMM6	2.9771	24.8256	9.9261
65	334MMM6	4.0416	26.4343	10.5495
66	33EE5	4.2426	24.9705	9.2879

Table 1. (Continued)

Sl. no.	Alkane	L_0	L_1	L_2
67	223MME5	4.0193	25.8941	10.3089
68	233MME5	4.0646	27.1085	10.5802
69	234MEM5	4.0913	22.8649	7.9894
70	2233(M)5	3.8106	32.2624	14.1382
71	2234(M)5	3.2766	28.14	11.6739
72	2244(M)5	3.7071	29.0989	13.3379
73	2334(M)5	3.8867	29.2546	11.8695

This trend in change is also observed for higher orders of L_i . When a methyl group is a pendant to an alkyl chain, the increment in the L_0 varies with degree of the attached carbon and position in the alkyl chain. With increasing order, the parameters are higher in even orders (0, 2, 4 etc) than the odd orders (1, 3, etc). There is an increasing trend in the parameters for branched alkanes while the data for normal chain exhibit a decreasing trend.

Further, L_i has been correlated with θ_i and the extent of correlation has been presented in a correlation matrix (Table 2). L_0 is found to have orthogonal relationship with higher order index of both weighted and unweighted line graph parameters, while it has a good relationship with the θ_0 . The parameters of higher order have a good interrelationship with each other.

Table 2. Correlation matrix of weighted line graph Indices and Bertz Indices.

	L_0	L_1	L_2	θ_0	θ_1	θ_2	θ_3	θ_4
L_0	1							
L_1	0.51	1						
L_2	0.28	0.96	1					
θ_0	0.96	0.71	0.52	1				
θ_1	0.57	0.99	0.94	0.77	1			
θ_2	0.28	0.97	0.99	0.51	0.93	1		
θ_3	0.18	0.91	0.96	0.39	0.84	0.98	1	
θ_4	0.13	0.85	0.90	0.33	0.77	0.93	0.99	1

4. APPLICATION OF L_i IN QSPR STUDIES OF ALKANES

With a view to investigate the applicability of the parameters in structure property relationships, various physicochemical properties like boiling point (BP), molar volume (MV), molar refraction (MR), enthalpy of vapourization (HV), critical temperature (TC) and surface tension (ST) have been correlated with these parameters. In a single parametric

equation, the correlations with L_0 are found to be significant and better than with that of L_1 and L_2 . Though scattered, the plots of the physicochemical parameters with L_1 and L_2 show a trend of ordination of the data, higher clarity is observed with L_2 than L_1 .

In a single parametric equation, the BP with L_0 has high predictability with a regression coefficient (R^2) of 0.98 and F of 2249.2. However, with L_1 and L_2 , the regression coefficients decrease to 0.71 and 0.48 respectively. The plots of L_1 and L_2 vs boiling point exhibit a grouping of the compounds in accordance with the structure of the molecules, with more clarity in the plot with L_2 for grouping (Figure 3). Addition of one methyl group as a pendant to the parent alkyl chain constitutes another class of compounds with co-linearity in the plot. Further branching in the alkyl chain leads to several groups, which were identified and accordingly *ad hoc* indicators of zero and one were assigned for the absence and presence of the branching (Table 3). The contribution of L_2 varies to an extent of 1.644 times on addition of an alkyl group, while addition of another alkyl group at any other position in the alkyl chain adds the contribution to different extent depending on the distance from the first alkyl group. Interestingly, the changes are in an order as presented in Table 1. By considering the extent of contribution, another *ad hoc* substituent parameter (SP) has been derived which reveals the exact extent of contribution of the substituent towards the activity i.e. instead of using 1 and 0 for the presence and absence of a substituent, SP and 0 have been used. When the data of all the 73 alkanes were subjected to multiple regression analysis, the 'r' value increased significantly than that obtained from single parametric equation (i.e. from 0.49 to 0.97). By using the regression model, the BPs have been calculated and plotted against the experimental values to obtain a linear graph (Figure 4).

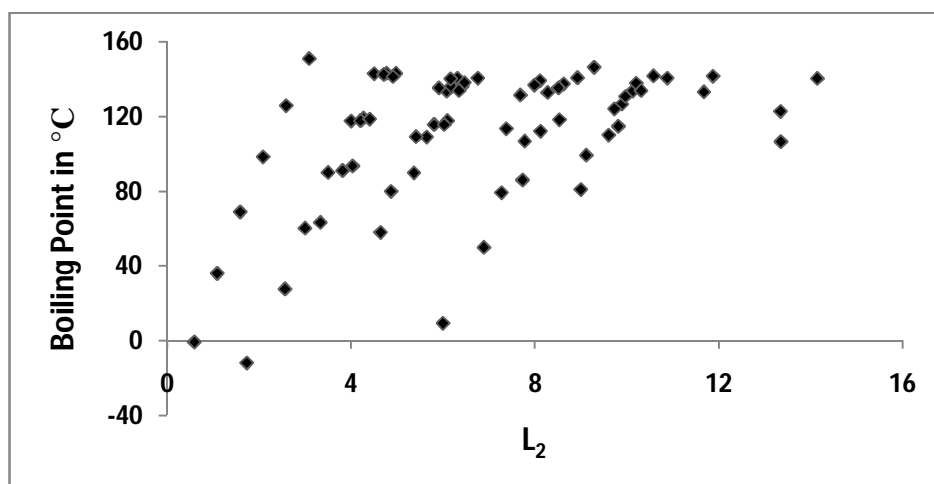

Figure 3. Plot of BP versus L_2 for C3-C9 hydrocarbons.

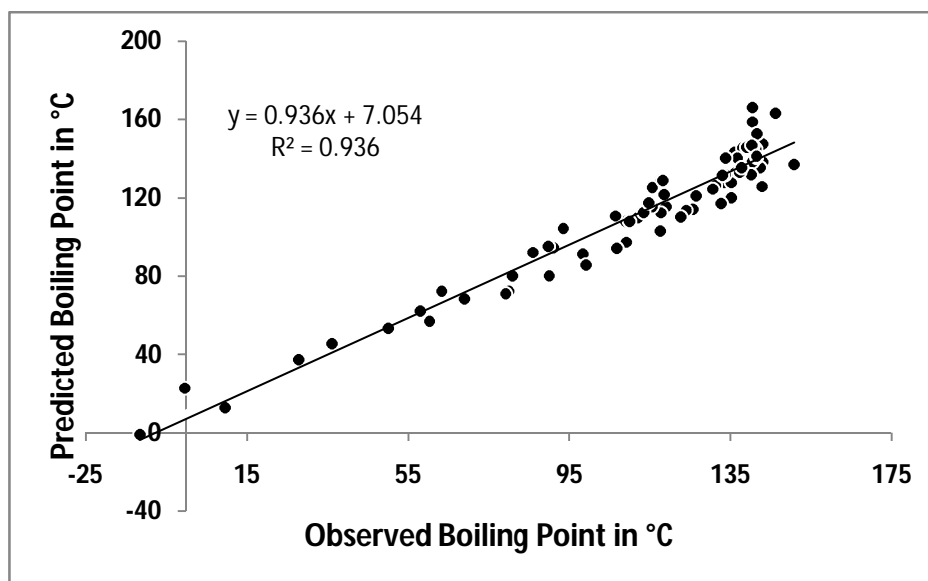

Figure 4. Plot of predicted BP versus observed BP.

Table 3. Topological parameters used in the present study.

Sl.No.	Alkane	L_2	IP_{mono}	$IP_{di, ij}$	$IP_{di, ii}$	$IP_{tri, iij}$	$IP_{tri, ijk}$	$IP_{tetra, iijk}$	$IP_{tetra, iijj}$	SP
1	4	0.5946	0	0	0	0	0	0	0	0
2	5	1.0905	0	0	0	0	0	0	0	0
3	6	1.5905	0	0	0	0	0	0	0	0
4	7	2.0905	0	0	0	0	0	0	0	0
5	8	2.5905	0	0	0	0	0	0	0	0
6	9	3.0905	0	0	0	0	0	0	0	0
7	2M3	1.732	1	0	0	0	0	0	0	1.64
8	2M4	2.5656	1	0	0	0	0	0	0	1.64
9	2M5	3.4377	1	0	0	0	0	0	0	1.64
10	3M5	3.3337	1	0	0	0	0	0	0	1.64
11	2M6	3.5012	1	0	0	0	0	0	0	1.64
12	3M6	3.6531	1	0	0	0	0	0	0	1.64
13	3E5	4.0347	1	0	0	0	0	0	0	1.64
14	2M7	4.0012	1	0	0	0	0	0	0	1.64
15	3M7	4.2496	1	0	0	0	0	0	0	1.64
16	4M7	4.2078	1	0	0	0	0	0	0	1.64
17	3E6	3.9404	1	0	0	0	0	0	0	1.64
18	2M8	4.5012	1	0	0	0	0	0	0	1.64
19	3M8	4.7728	1	0	0	0	0	0	0	1.64
20	4M8	4.7099	1	0	0	0	0	0	0	1.64
21	3E7	4.9772	1	0	0	0	0	0	0	1.64
22	4E7	4.9157	1	0	0	0	0	0	0	1.64
23	23MM4	4.6451	0	1	0	0	0	0	0	3.16
24	23MM5	4.9465	0	1	0	0	0	0	0	3.16
25	24MM5	4.8693	0	1	0	0	0	0	0	3.16
26	23MM6	5.8086	0	1	0	0	0	0	0	3.16
27	24MM6	5.1745	0	1	0	0	0	0	0	3.16

Table 3. (Continued)

Sl.No.	Alkane	L_2	IP _{mono}	IP _{di, ij}	IP _{di, ii}	IP _{tri, iij}	IP _{tri, ijk}	IP _{tetra, iijk}	IP _{tetra, iiii}	SP
28	25MM6	5.4136	0	1	0	0	0	0	0	3.16
29	34MM6	6.0973	0	1	0	0	0	0	0	3.16
30	3E2M5	6.026	0	1	0	0	0	0	0	3.16
31	23MM7	6.3107	0	1	0	0	0	0	0	3.16
32	24MM7	5.9611	0	1	0	0	0	0	0	3.16
33	25MM7	6.1852	0	1	0	0	0	0	0	3.16
34	26MM7	5.4038	0	1	0	0	0	0	0	3.16
35	34MM7	6.1675	0	1	0	0	0	0	0	3.16
36	35MM7	6.4164	0	1	0	0	0	0	0	3.16
37	23ME6	6.4684	0	1	0	0	0	0	0	3.16
38	24ME6	6.349	0	1	0	0	0	0	0	3.16
39	34EM6	6.7568	0	1	0	0	0	0	0	3.16
40	22MM3	6	0	0	1	0	0	0	0	5.57
41	22MM4	6.8878	0	0	1	0	0	0	0	5.57
42	22MM5	7.2736	0	0	1	0	0	0	0	5.57
43	33MM5	7.3471	0	0	1	0	0	0	0	5.57
44	22MM6	7.3188	0	0	1	0	0	0	0	5.57
45	33MM6	7.7959	0	0	1	0	0	0	0	5.57
46	3E3M5	8.5333	0	0	1	0	0	0	0	5.57
47	22MM7	8.2773	0	0	1	0	0	0	0	5.57
48	33MM7	8.6254	0	0	1	0	0	0	0	5.57
49	44MM7	8.5108	0	0	1	0	0	0	0	5.57
50	33ME6	8.9254	0	0	1	0	0	0	0	5.57
51	33EE5	9.2879	0	0	1	0	0	0	0	5.57
52	234MMM5	7.3782	0	0	0	1	0	0	0	4.78
53	235MMM6	7.6815	0	0	0	1	0	0	0	4.78
54	234MMM6	8.1073	0	0	0	1	0	0	0	4.78
55	234MEM5	7.9894	0	0	0	1	0	0	0	4.78
56	223MMM4	8.9967	0	0	0	0	1	0	0	7.08
57	223MMM5	9.606	0	0	0	0	1	0	0	7.08
58	224MMM5	9.1144	0	0	0	0	1	0	0	7.08
59	233MMM5	9.4125	0	0	0	0	1	0	0	7.08
60	223MMM6	10.1274	0	0	0	0	1	0	0	7.08
61	224MMM6	9.4038	0	0	0	0	1	0	0	7.08
62	225MMM6	9.7283	0	0	0	0	1	0	0	7.08
63	233MMM6	10.1603	0	0	0	0	1	0	0	7.08
64	244MMM6	9.9261	0	0	0	0	1	0	0	7.08
65	334MMM6	10.5495	0	0	0	0	1	0	0	7.08
66	223MME5	10.3089	0	0	0	0	1	0	0	7.08
67	233MME5	10.5802	0	0	0	0	1	0	0	7.08
68	2234(M)5	11.6739	0	0	0	0	0	1	0	8.62
69	2334(M)5	11.8695	0	0	0	0	0	1	0	8.62
70	2233[M]4	13.3486	0	0	0	0	0	0	1	10.73
71	2244(M)5	13.3379	0	0	0	0	0	0	1	10.73
72	2233(M)5	14.1382	0	0	0	0	0	0	1	10.73

In a similar manner, the regression models for MV, MR, HV and TC have been derived and validated by plotting the experimental values with corresponding predicted ones.

Table 4. Substituent parameters for different substituent systems (i, j and k refers to different positions in alkyl chain).

Substituent Class	BP	MV	MR	HV	TC	ST	Avg
mono	-1.64398	-1.49541	-1.52473	-1.75967	-1.63573	-1.79132	-1.64181
di, ij	-3.21345	-2.88686	-2.93939	-3.37515	-3.16243	-3.43591	-3.16886
di, ii	-5.61992	-5.31345	-5.34529	-5.85768	-5.51497	-5.80522	-5.57609
tri, iij	-4.85451	-4.52648	-4.52497	-5.07623	-4.71461	-4.99049	-4.78121
tri, ijk	-7.15906	-6.7536	-6.77588	-7.44858	-6.98943	-7.37762	-7.08403
tetra, iijk	-8.68151	-8.4716	-8.35776	-9.03878	-8.44581	-8.75954	-8.62583
tetra, iijj	-10.8251	-10.334	-10.2909	-11.245	-10.7316	-10.9818	-10.7347

Table 5. Parameters of regression model for a generalized equation $P = a_1SP + a_2L_2 + b$.

Property (P)	a_1	a_2	b	R^2	F	R
BP	-46.1278	45.69424	-4.31214	0.936164	505.945	0.967556
MV	-20.355	20.91467	105.3214	0.756663	102.6142	0.869864
MR	-6.48603	6.699057	20.98696	0.849288	185.9611	0.921568
HV	-7.89501	7.552183	20.35447	0.904482	312.4834	0.951042
TC	-54.5066	55.10284	143.1268	0.958869	804.2879	0.979219
ST	-3.02048	2.964773	13.27821	0.950235	620.5757	0.9748

The surface tension of a liquid, being an interfacial phenomenon, is found to have poor relationship with the chemical structure. The best relationship had been obtained by using parameters derived from line graph [9]. The use of weighted line graph parameter was found to be more fruitful with a significant increase in the R^2 and F value (Table 5). It seems obvious because these parameters relate to the branched alkyl groups which are mostly responsible for the interfacial activity.

Thus, weighted line graph is found to be a promising tool for enumerating molecular descriptors for both carbonaceous as well as heteroatomic systems to be used in QSP/AR studies.

Acknowledgement. BKM thanks University Grant Commission (New Delhi) for financial support through Basic Science Research Faculty Fellowship and Emeritus Fellowship.

REFERENCES

1. R. Todeschini and V. Consonni, *Handbook of Molecular Descriptors*, Wiley VCH, Weinheim. 2000.

2. R. K. Mishra and B. K. Mishra, A critical assessment of closed- and open-shell heterocyclobutadienes, *Chem. Phys. Lett.* **151** (1988) 44–46.
3. F. Harary, *Graph Theory*, Addison Wesley Publishing Company, New York, 1969.
4. S. H. Bertz in: *Chemical Applications of Topology and Graph Theory*, R. B. King (Ed.), Elsevier, Amsterdam, 1993, p. 206.
5. S. H. Bertz, Branching in graphs and molecules, *Discrete Appl. Math.* **19** (1988) 65–83.
6. I. Gutman, L. Popović, B. K. Mishra, M. Kuanar and E. Estrada, Application of line graphs in physical chemistry. Predicting the surface tensions of alkanes, *J. Serb. Chem. Soc.* **62** (1997) 1025–1030.
7. M. Kuanar, S. K. Kuanar, B. K. Mishra and I. Gutman, Correlation of line graph parameters with physicochemical properties of octane isomers, *Indian J. Chem.* **38A** (1999) 525–528.
8. I. Gutman and Z. Tomovic, On the application of line graphs in quantitative structure-property studies, *J. Serb. Chem. Soc.* **65** (2000) 577–580.
9. I. Gutman, Z. Tomovic, B. K. Mishra and M. Kuanar, On the use of iterated line graphs in quantitative structure-property studies, *Indian J. Chem.* **40A** (2001) 4–11.
10. Z. Tomovic and I. Gutman, Modeling boiling points of cycloalkanes by means of iterated line graph sequences, *J. Chem. Inf. Comput. Sci.* **41** (2001) 1041–1045.
11. E. Estrada, Modelling the diamagnetic susceptibility of organic compounds by a sub-structural graph-theoretical approach, *J. Chem. Soc. Faraday Trans.* **94** (1998) 1407–1410.
12. E. Estrada, A computer-based approach to describe the ^{13}C NMR chemical shifts of alkanes by the generalized spectral moments of iterated line graphs, *Comput. Chem.* **24** (2000) 193–201.
13. I. Gutman and E. Estrada, Topological indices based on the line graph of the molecular graph, *J. Chem. Inf. Comput. Sci.* **36** (1996) 541–543.
14. E. Estrada, Application of a novel graph-theoretic folding degree index to the study of steroid–DB3 antibody binding affinity, *Comp. Biol. Chem.* **27** (2003) 305–313.
15. N. Guevara, Fragmental graphs. A novel approach to generate a new family of descriptors. Applications to QSPR studies, *J. Mol. Struct. (THEOCHEM)* **493** (1999) 29–36.
16. A. A. Dobrynin and L. S. Mel'nikov, Wiener index for graphs and their line graphs with arbitrary large cyclomatic numbers, *Appl. Math. Lett.* **18** (2005) 307–312.
17. H. S. Ramane, K. P. Narayankar, S. S. Shirkol and A. B. Ganagi, Terminal Wiener index of line graphs, *MATCH Commun. Math. Comput. Chem.* **69** (2013) 775–782.
18. A. A. Dobrynin and L. S. Mel'nikov, Wiener index of generalized stars and their quadratic line graphs, *Discuss. Math. Graph Theory* **26** (2006) 161–175.

19. B. Wu, Wiener index of line graphs, *MATCH Commun. Math. Comput. Chem.* **64** (2010) 699–706.
20. H. S. Ramane, I. Gutman and A. B. Ganagi, On diameter of line graphs, *Iran. J. Math. Sci. Inf.* **8** (2013) 105–109.
21. A. A. Dobrynin and L. S. Mel'nikov, Trees and their quadratic line graphs having the same Wiener index, *MATCH Commun. Math. Comput. Chem.* **50** (2004) 145–164.
22. A. A. Dobrynin and L. S. Mel'nikov, Some results on the Wiener index of iterated line graphs, *Electronic Notes Discrete Math.* **22** (2005) 469–475.
23. M. Knor, P. Potočnik and R. Škrekovski, Wiener index of iterated line graphs of trees homeomorphic to H, *Discrete Math.* **313** (2013) 1104–1111.
24. A. A. Dobrynin, R. Entringer and I. Gutman, Wiener index of trees: theory and applications, *Acta Appl. Math.* **66** (2001) 211–249.
25. A. A. Dobrynin and L. S. Mel'nikov, Wiener index, line graphs and the cyclomatic number, *MATCH Commun. Math. Comput. Chem.* **53** (2005) 209–214.
26. M. Knor, P. Potočnik and R. Škrekovski, The Wiener index in iterated line graphs, *Discrete Appl. Math.* **160** (2012) 2234–2245.
27. M. Knor, P. Potočnik and R. Škrekovski, On a conjecture about Wiener index in iterated line graphs of trees, *Discrete Math.* **312** (2012) 1094–1105.
28. P. Dankelmann, I. Gutman, S. Mukwembi and H. C. Swart, The edge-Wiener index of a graph, *Discrete Math.* **309** (2009) 3452–3457.
29. S. M. Free and J. W. Wilson, A mathematical contribution to structure-activity studies, *J. Med. Chem.* **7** (1964) 395–399.
30. D. R. Lide, *CRC Handbook of Chemistry and Physics*, 73rd Ed., CRC Press, Boca Raton, FL, 1992.
31. D. E. Needham, I. C. Wei and P. G. Seybold, Molecular modeling of the physical properties of alkanes, *J. Am. Chem. Soc.* **110** (1988) 4186–4194.